

Know what's on display.
Gain customer insight.
No matter where you are.



InVue InsightSM is an enterprise retail analytics solution that helps provide visibility to in-store activity of your smartphones and tablets on display. With an intelligent, networked POD you

can track planogram compliance, customer interaction (how many lifts and for how long) and security status — all through a cloud-based portal.



FEATURES AND BENEFITS

- 1 Works with iOS and Android devices
- 2 Connect up to 16 devices using the Insight Hub and an additional 16 when connected to the Insight Expansion Box (Insight Hub shown below)
- 3 Information can be accessed at the device, store, and enterprise levels

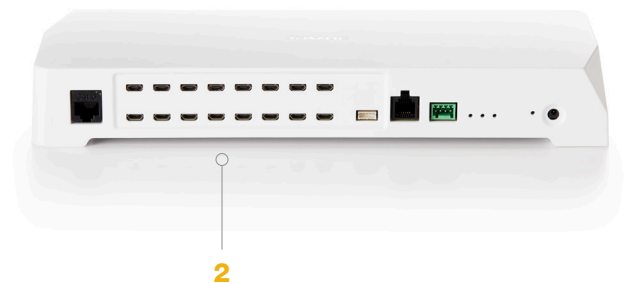

INSIGHT SYSTEM OVERVIEW

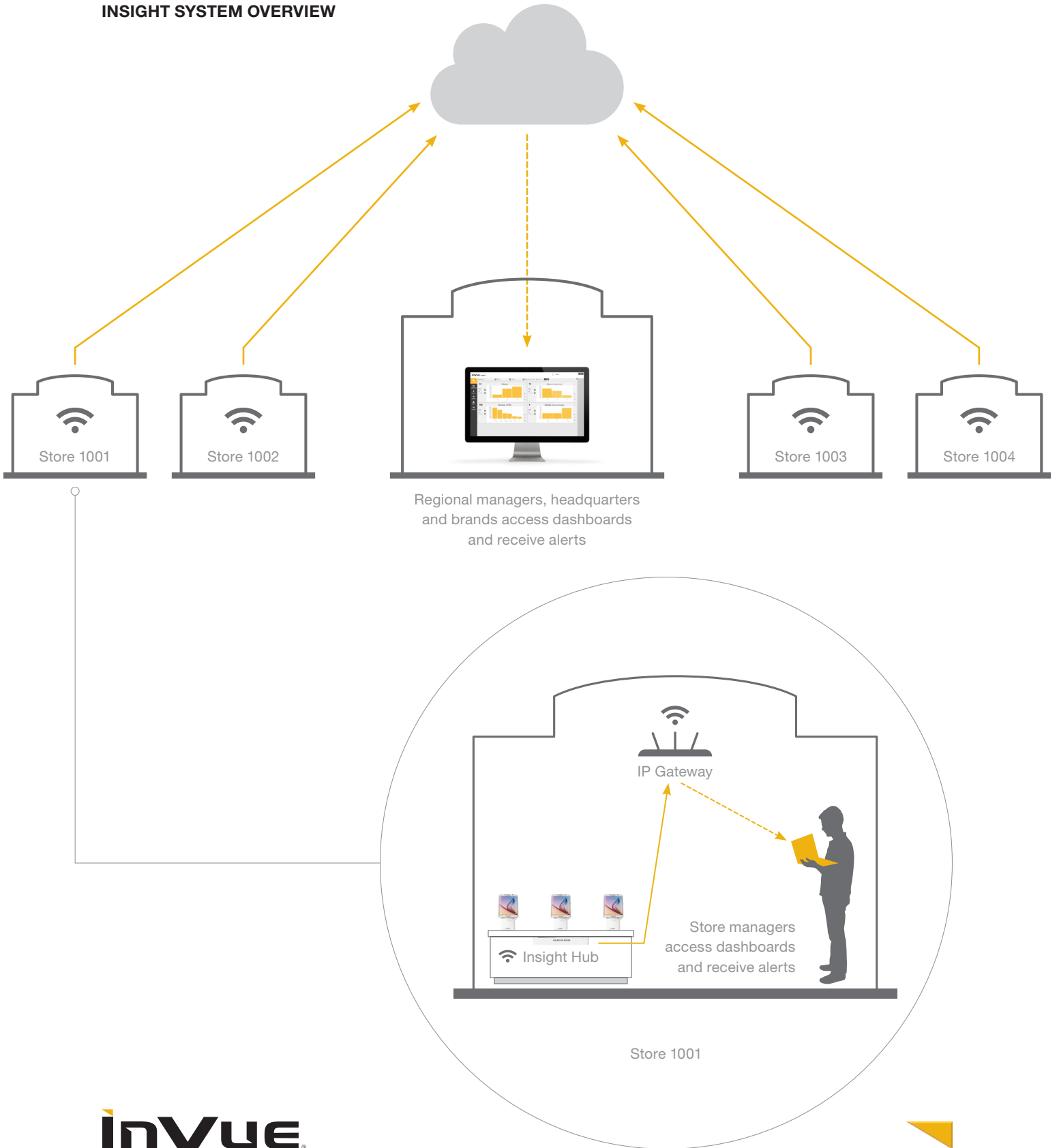

INSIGHT SYSTEM ANALYTICS EXAMPLES

With an intelligent, networked POD we provide the following through a cloud-based portal:

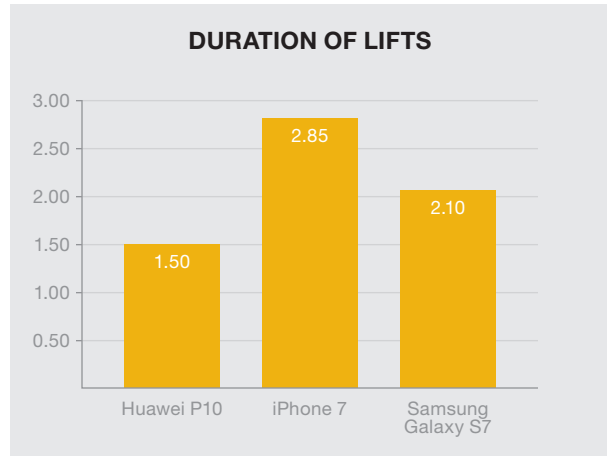
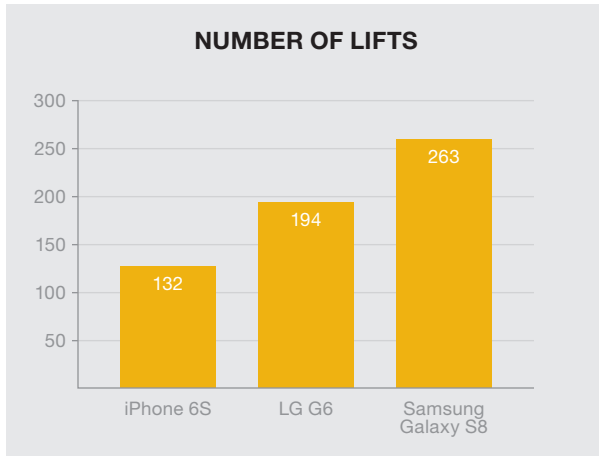

› *Activity:* Lifts and lift duration of merchandise

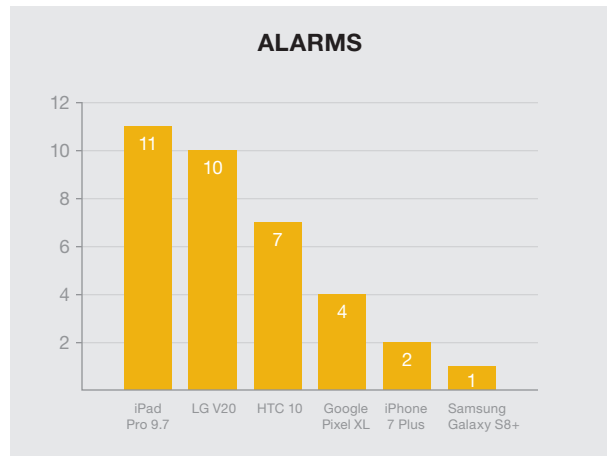
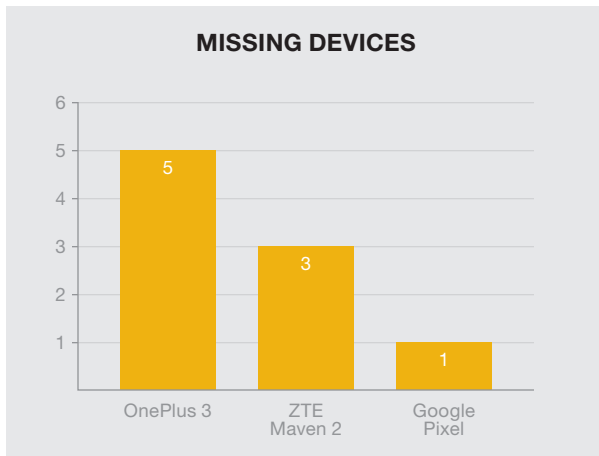

› *Planogram:* Type of device (e.g., brand and model) on each POD and missing devices

› *Security:* Arm/disarm and alarm events

› *System health:* Power and communication status (future)

This information can be easily accessed at the device, store, and enterprise level.



INSIGHT SYSTEM MONITORING

Notifications:

- › Device is missing
- › Device is receiving considerably more (or less) activity than normal
- › Position is not re-armed after the alarm sounds

Communication method:

- › Configured for text or email
- › Customizable

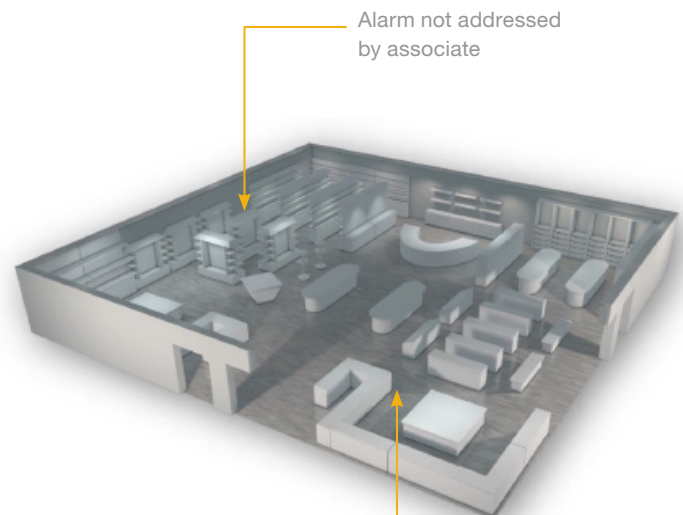

Store experiencing more device interactions than usual



SPECIFICATIONS

Insight Hub (INS1000-W):

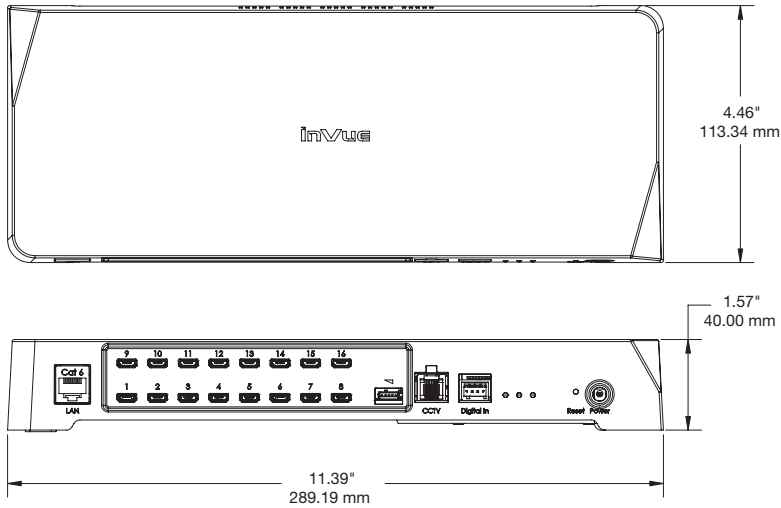

Insight Expansion Box (INS2000-W):

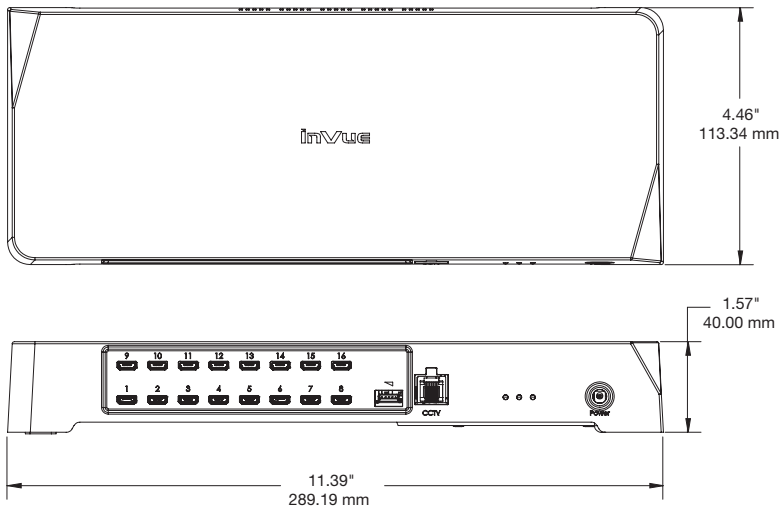

SPECIFICATIONS

Insight Expansion/Hub Data Cable Adapter USB Male (INS3001-W):

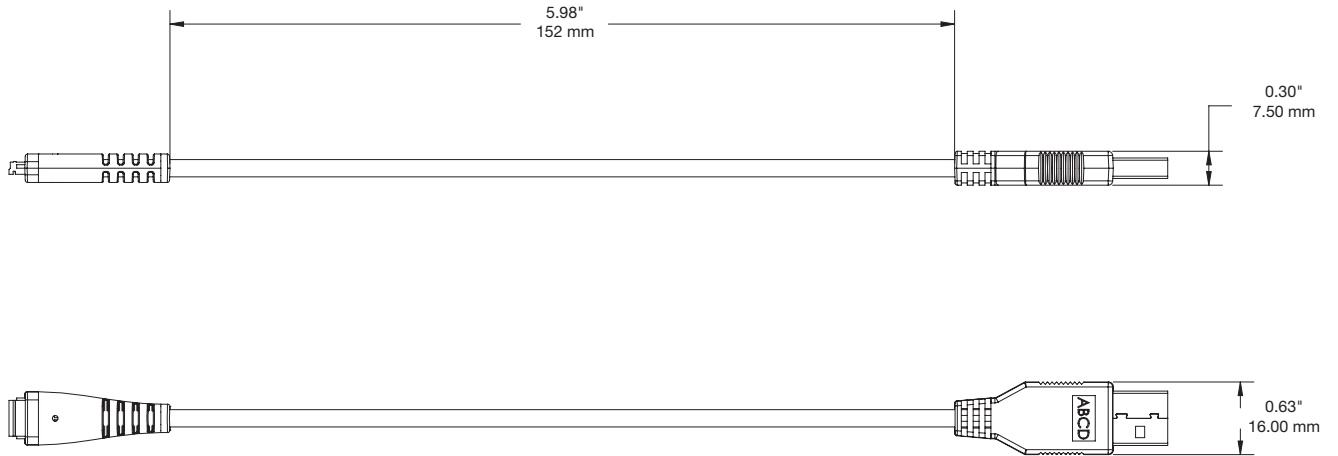

Insight Expansion/Hub Data Cable Adapter USB Female (INS3002-W):

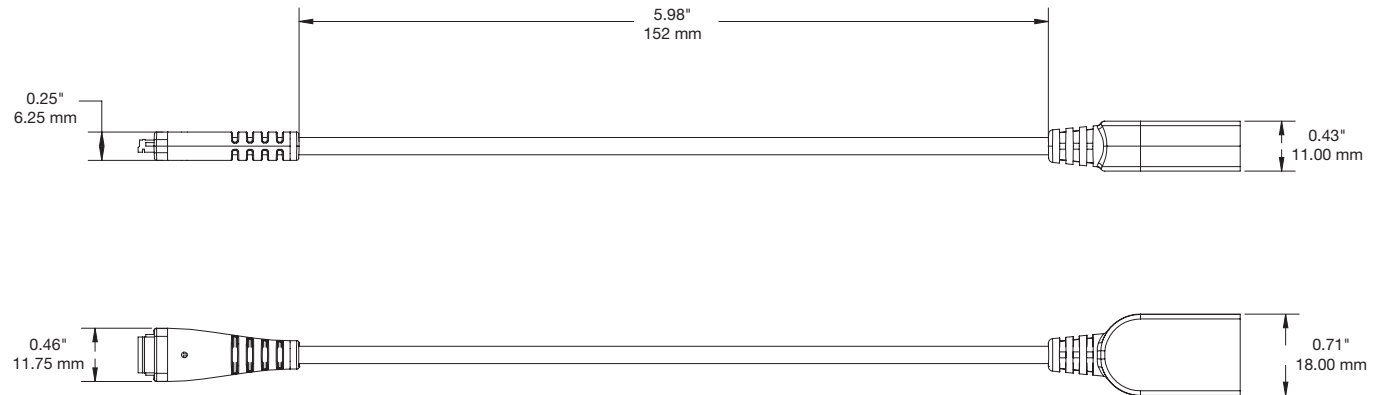

SPECIFICATIONS

5M Insight Expansion Box/Hub Data Cable (INS3100-W):

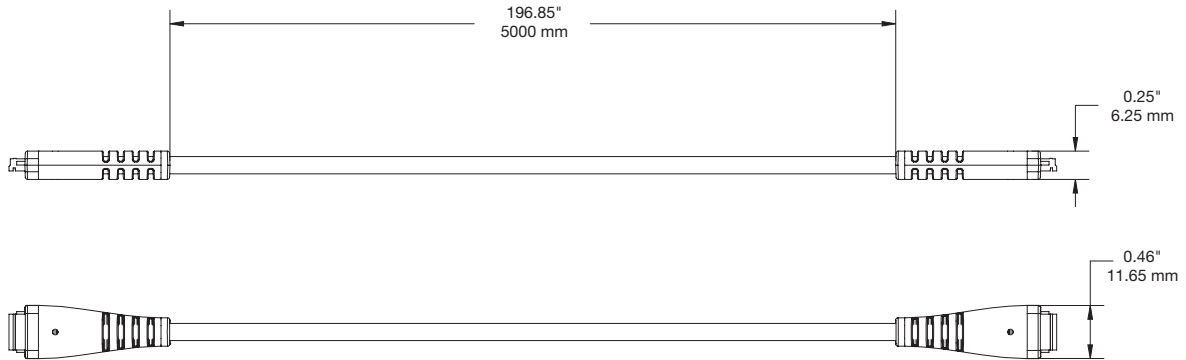

5M Insight POD/Hub Data Cable Under Counter (INS3200-W):

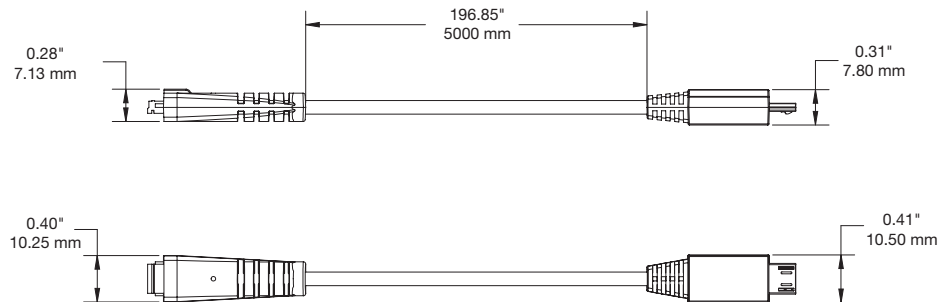

SPECIFICATIONS

5M Insight Hub/POD Data Cable Over Counter (INS3210-W):

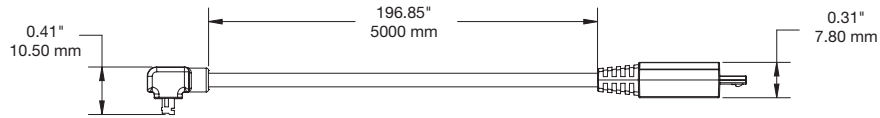

2.5M Insight POD/Hub Data Cable Under Counter (INS3300-W):

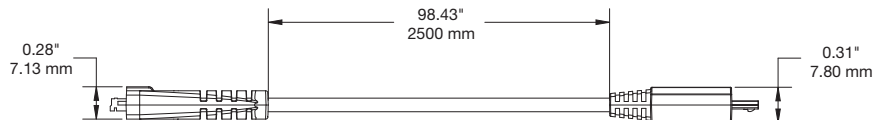

SPECIFICATIONS

2.5M Insight Hub/POD Data Cable Over Counter (INS3310-W):

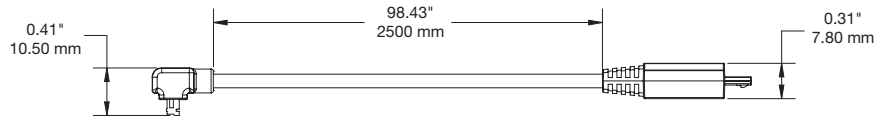

Series 1060 Flat Stand (DRD100-W):

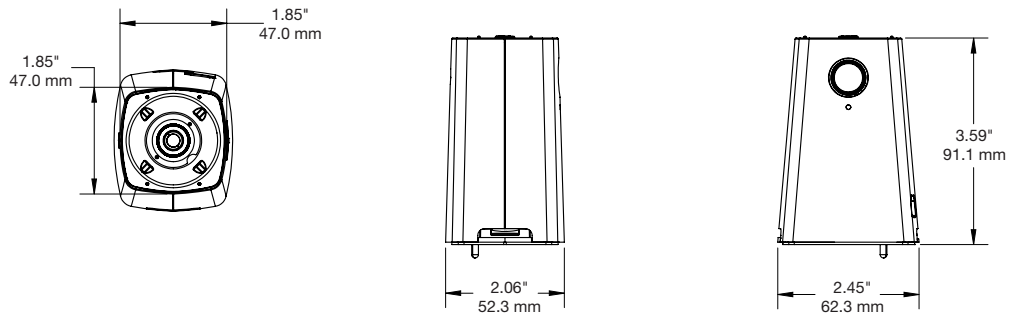

SPECIFICATIONS

Series 1060 Angled Stand (DRD101-W):

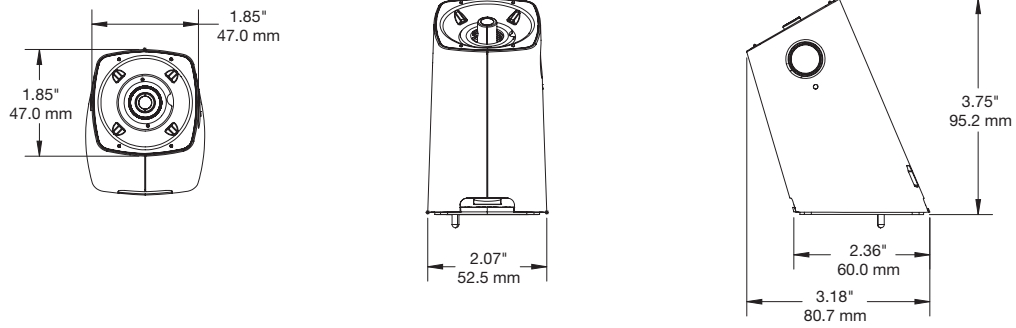

Series 1560 Angled Alarming Stand (DSD100-W):

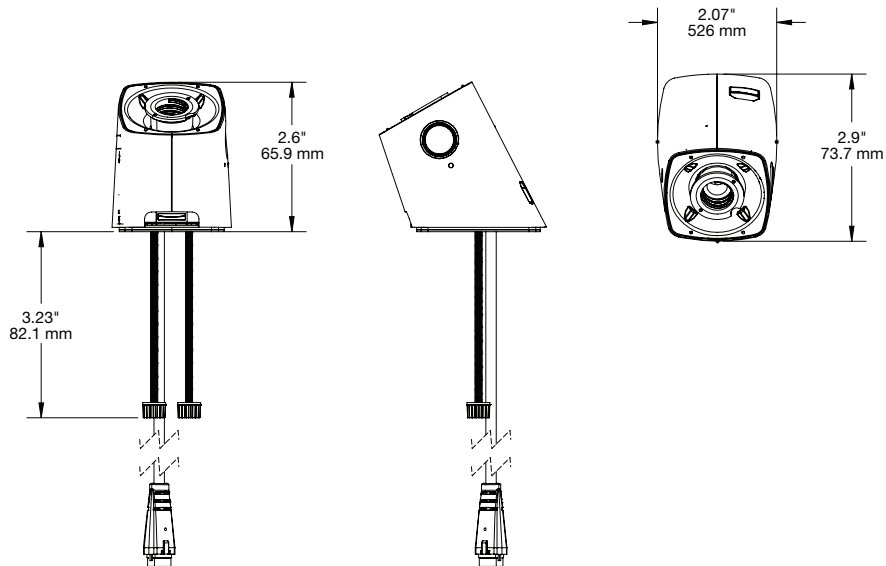

SPECIFICATIONS

Series 1560 Zero Degree Alarming Stand (DSD101-W):

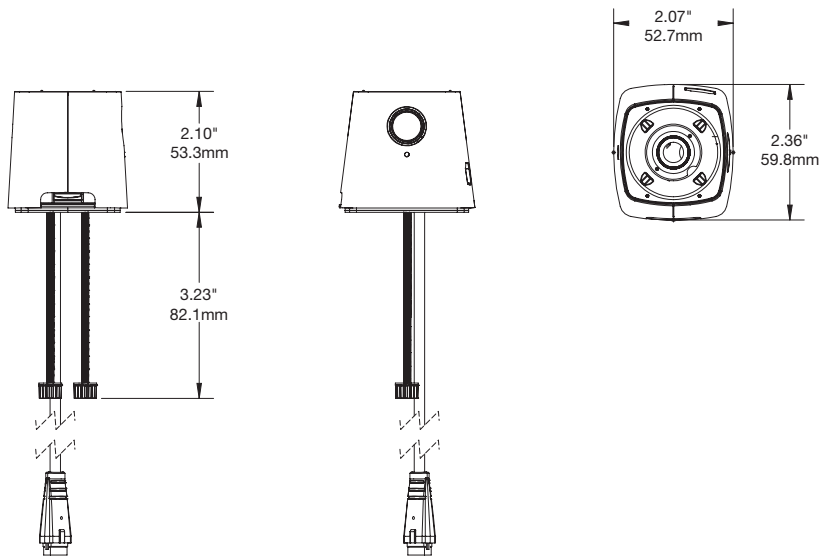

Series 1560 Recoiler (DSD300-W):

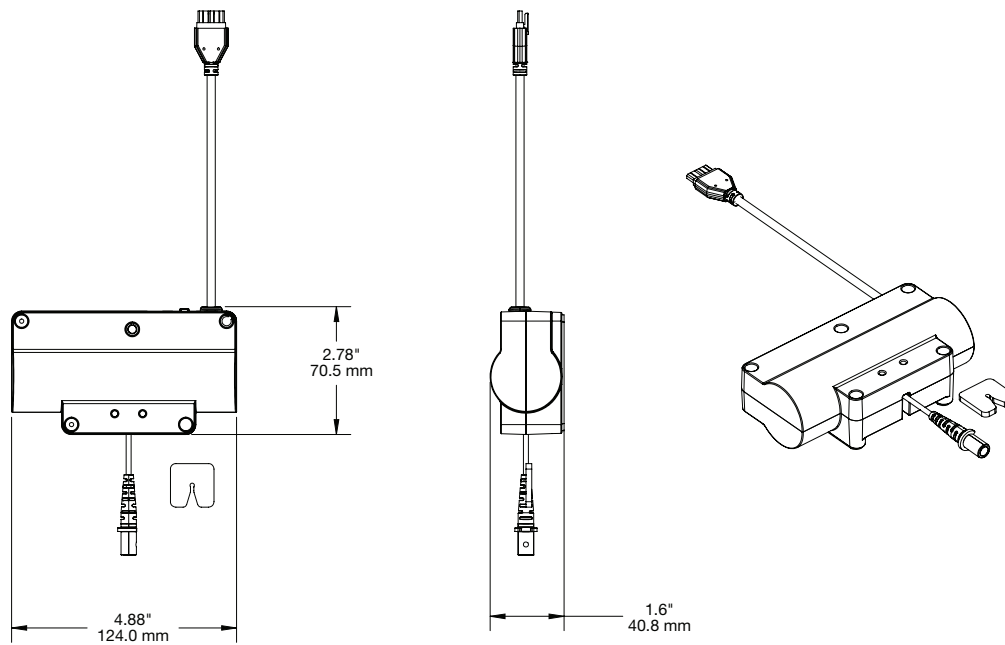

PRODUCT ORDERING

ORDER CODE	DESCRIPTION
INS1000-W	Insight Hub - White
INS2000-W	Insight Expansion Box - White
INS3001-W	Insight Expansion Box/Hub Data Cable Adapter USB Male - White
INS3002-W	Insight Expansion Box/Hub Data Cable Adapter USB Female - White
INS3100-W	5M Insight Expansion/Hub Data Cable - White
INS3200-W	5M Insight POD/Hub Data Cable Under Counter - White
INS3210-W	5M Insight Hub/POD Data Cable Over Counter - White
INS3300-W	2.5M Insight POD/Hub Data Cable Under Counter - White
INS3310-W	2.5M Insight Hub/POD Data Cable Over Counter - White
INS4000-B	USB-A to Insight Power Connector - Black
DRD100-W	Series 1060 Flat Stand - White
DRD101-W	Series 1060 Angled Stand - White
DSD100-W	Series 1560 Angled Alarming Stand - White
DSD101-W	Series 1560 Zero Degree Alarming Stand - White
DSD300-W	Series 1560 Recoiler - White
PS515-US	5V USB-A Positive Slope Power Supply - United States
PS515-UK	5V USB-A Positive Slope Power Supply - United Kingdom
PS515-JPN	5V USB-A Positive Slope Power Supply - Japan
PS515-EU	5V USB-A Positive Slope Power Supply - Europe
PS515-AUS	5V USB-A Positive Slope Power Supply - Australia

**Multiple sensors supporting iOS and Android devices sold separately.*

invue.com

©2017 InVue Security Products. No endorsement of InVue products has been made by any of the manufacturers of the products shown. Product is sold pursuant to InVue's warranty which can be found at www.invue.com/warranty.

THE AMERICAS 704.752.6513 • 888.55.INVUE

EUROPE, MIDDLE EAST & AFRICA +31.23.8900150

ASIA PACIFIC +852.3127.6811

